



## **Network Loss Factor Methodology**

**Date: 22 February 2008**

# Table of Contents

<b>1.</b>	<b>Introduction .....</b>	<b>1</b>
<b>2.</b>	<b>Background .....</b>	<b>1</b>
<b>3.</b>	<b>Definitions and Abbreviations: .....</b>	<b>2</b>
<b>4.</b>	<b>Network Energy Losses .....</b>	<b>3</b>
4.1	Reconciliation Losses .....	3
4.2	Technical Losses.....	3
4.3	Low Voltage Network and Non-Technical Losses.....	4
<b>5.</b>	<b>Load Loss Factor .....</b>	<b>4</b>
<b>6.</b>	<b>DLFs Calculation .....</b>	<b>4</b>
6.1	Reconciliation Loss Factor .....	4
6.2	Site Specific Loss Factor .....	5
6.3	Sub-transmission Network (33kV lines) .....	5
6.4	Zone substation .....	6
6.5	HV Network (22/11/6.35 kV Lines).....	6
6.6	Distribution Transformers .....	6
6.7	Low Voltage Network.....	7
6.8	Embedded Generator .....	7
<b>7.</b>	<b>Reporting .....</b>	<b>7</b>
<b>8.</b>	<b>Summary: .....</b>	<b>8</b>

## 1. Introduction

The Electricity Governance Rules (EGR) require that Electricity Distributors must calculate and publish reconciliation loss factor (Distribution Loss Factor, DLF) for each loss factor code in the registry each year.

This report presents the DLFs that can be applied to customer's metered energy to recover upstream losses on Top Energy's Network (TEN) for the year 2008-09. It also outlines methodology, assumptions and data used for the calculation of the loss factors.

The methodology used in this calculation is based on the requirements set out in the Electricity Commission's (The Commission) Report "*Guidelines on the calculation and the use of loss factors for reconciliation purposes V1.0<sup>1</sup>*" issued on 15/07/2007 as a draft for consultation. The methodology used is very similar to that used by Top Energy last year but in line with the methodology proposed in the consultation paper. The most recently available energy injection and consumption data for last 24 months is used for this calculation. The peak demand data for the calculation is extracted from the most recently available SCADA data and forecast demand as disclosed in Top Energy's Asset Management Plan-2007. The Network model is built in the DigSilent Powerfactory software up to HV terminal of distribution transformers to calculate the Technical Losses at each stage of the Network.

This document can be made available from Top Energy's web site at [www.topenergy.co.nz](http://www.topenergy.co.nz).

## 2. Background

Electrical Energy losses are losses incurred in the transfer of electricity over a distribution network. Losses increases with line length and depends on the amount of power being transferred. Overall losses can vary from year to year as they depend on factors such as network configuration, utilization level, the load profile and the power factor of the system (the level of reactive power support).

It is important to calculate the losses attributable to the customers connected at each stage of the Network so they can be charged for the portion of the losses incurred to supply the customer's demand. Due to the vast number and diversity of the customers connected to the distribution network, it is not feasible either to measure or to calculate the losses caused by each individual customer.

A DLF, normally expressed as a multiplier, is used to estimate the difference between metered quantities at the input to a network and the sum of metered quantities at the meters of customers averaged over a period of time. The DLF is calculated as  $1/(1-\text{loss ratio})$  where the loss ratio equals the average proportion of losses over a network.

EGR require that DLF will be either site specific for certain types of connection points or for those which are not required to be site specific (Non-site specific), based on voltage or connection point classes. The site specific DLFs will be determined for a connection point:

- a. for an embedded generating unit with actual generation of more than 10MW;
- b. for an end-user with actual or forecast load of more than 40GWh or an electrical demand of more than 10MW;
- c. for a market network service provider;
- d. between two or more distribution network; and
- e. for different voltage levels ( as the distributor deems appropriate).

---

<sup>1</sup> This document can be made available from <http://www.electricitycommission.govt.nz/pdfs/opdev/retail/consultationdocs/pdfsconsultation/Loss-methodology.pdf>. This document contains detail requirements and criteria required by The Commission for loss factor calculation.

The DLFs calculated in this report are to be applied to the metered energy at each stage of the Network. The DLFs represent the energy losses at any stage of the network expressed as a percentage of the energy delivered at that level of the network, irrespective of whether it is delivered to customers at the same stage or to customers at the lower stage of the network.

### **3. Definitions and Abbreviations:**

1. EGR: The Electricity Governance Rules
2. DLF : Distribution Loss Factor
3. Embedded Generation: A generator which operates one or more generating units that are directly connected to a distribution network and injects energy into a distribution network.
4. SCADA: Supervisory Control And Data Acquisition: SCADA systems are typically used to perform data collection and control at the supervisory level in a distribution network.
5. LLF: Load Loss Factor: The LLF is the ratio between the instantaneous losses incurred at the peak load and the average instantaneous losses over a year.
6. GXP : Grid Exist Point
7. ICC: Individually Calculated Customers: The customer for which EGR require site-specific loss factor to be calculated.
8. Utilisation Factor: Utilisation factor is the ratio of the maximum coincident KVA demand on the component to the rating of the component.
9. LV : Low Voltage
10. HV: High Voltage

## 4. Network Energy Losses

Network Energy losses are categorized mainly in three different categories as following:

### 4.1 Reconciliation Losses

EGR require Reconciliation losses to be calculated from the immediate past 24 months energy injection and consumption information for an electrically connected network. These losses are basically the difference between purchased and sold energy in the network. Top Energy considers energy injection from Transpower at both GXPx and also energy injection from Ngawha Generators at sub-transmission level to calculate these losses for entire network.

### 4.2 Technical Losses

There are mainly two components of technical losses on a distribution network.

- a. **Load losses:** These losses depend on the electricity being supplied through the distribution network. These losses are proportional to square of the current being supplied through the network equipment such as sub-transmission, distribution and, LV lines, zone substation and distribution transformers. These losses are also known as copper losses or  $I^2R$  losses.
- b. **No-Load losses:** These losses are fixed and do not depend on the load. These losses arise from the standing or Iron losses of the Network transformers (Zone substation and Distribution).

In general, the Load losses are calculated on the relevant part of the network under peak demand condition using DigSilent PowerFactory load flow package. The associated energy losses are calculated from these losses by using appropriate Load Loss Factor<sup>II</sup> (LLF) as follows:

$$\text{Load Losses (kWh)} = \text{Load Losses at Peak Demand (kW)} \times 8760 \text{ hrs} \times \text{LLF} \quad \text{I}$$

Peak Losses are modelled using peak demand forecast for the year 2008/09. To determine Load losses for TEN, the sub-transmission (33kV), Zone substation (33/11kV, 33/22kV), and the distribution (22kV, 11kV and 6.35kV) network up to HV terminals of distribution transformers are included in the model. This model also includes major 2-wire and SWER lines in the distribution network. The small spur lines in the distribution network are excluded in the model for simplicity, but 25% allowance is made for the part of the network which is not modelled explicitly.

The No-Load losses for Zone substation transformers are obtained from manufacturer's data sheets and test sheets to feed into DigSilent PowerFactory. The associated energy losses are calculated as follows:

$$\text{No-Load Losses (kWh)} = \text{No-Load Losses (kW)} \times 8760 \text{ hrs} \quad \text{II}$$

The LLF is not applied to No-Load losses as these losses are not dependent on the transformer loading.

The Load and No-Load losses for the distribution transformers are obtained from the manufacturer's data sheet and test sheets for different size of distribution transformers. The average losses are calculated for each size of distribution transformer that also includes SWER isolating transformers.

The energy losses associated with the Load losses for each type of distribution transformer is then calculated as follows and added together to get total energy losses:

---

II Load Loss Factor is explained in detail in Section 5.

$$\text{Load Losses (kWh)} = \text{Load Losses (kW) at Max. Rating} \times (\%UF)^2 \times LLF \times 8760 \text{ hrs} \quad \text{III}$$

The energy losses associated with the No-Load losses for each type of distribution transformer is calculated as per Equation II and added together to get total energy losses.

### 4.3 Low Voltage (LV) Network and Non-Technical Losses

EGR define the Non-Technical Losses as the difference between Reconciliation losses and Technical losses for entire network. These losses include unaccounted energy due to theft, meter inaccuracy and minor billing errors.

Due to lack of LV network loading and modelling data for TEN, it is impossible to calculate the Load losses using load flow studies. Top Energy calculates LV Network losses as a part of Non-Technical losses by subtracting all upstream losses from Reconciliation losses. Top Energy considers X% of Non-Technical losses for theft, meter inaccuracy and minor billing errors. It is assumed that all above mentioned Non-technical losses mainly occur at Low voltage level and therefore, only allocated to LV network customers. These losses also include losses in street light circuits.

$$\text{LV Energy Losses} = \text{Reconciliation Losses} - \text{Total Upstream Losses} \quad \text{IV}$$

## 5. Load Loss Factor

The LLF is the ratio between the average instantaneous losses over a year and the instantaneous losses incurred at the peak load. It is based on the square of the load and expressed as:

$$LLF = \frac{\sum_{n=1}^{17520} \left( \frac{Load_n^2}{PeakLoad^2} \right)}{17520} \quad \text{V}$$

Where: Load<sub>n</sub> = the 30 minutes average load in the nth period  
 17520 = the number of 30 minutes load recordings in one year  
 Peak load = the highest 30 minutes average load in the year

The LLFs are calculated for each zone substation, in both northern and southern Top Energy Network, for both Gird Exist Points (GXPs) and 3 big industrial customers in the network. These LLFs are calculated using SCADA data for last 24 months for all zone substation and GXPs, and metering data for big 3 industrial customers.

## 6. DLFs Calculation

This section briefly presents the methodology used to calculate the DLFs for site-specific customers, embedded generator and for each stage of the network.

### 6.1 Reconciliation Loss Factor

Reconciliation Loss factor is calculated using reconciliation losses as following:

$$DLF R = 1 + \frac{\text{Reconciliation Losses}}{\Sigma \text{ Energy Consumption (kWh) for Entire Network}} \quad \text{VI}$$

## 6.2 Site Specific Loss Factor

EGR require site-specific loss factors to be calculated for a customer (Individually calculated customers- ICC) with actual or forecast load of more than 40GWh per annum or an electrical demand of more than 10MW.

The Energy losses directly associated with an ICC depend on the point of connection on the network (i.e.: Sub-transmission level, Zone Substation level etc.). The losses need to be calculated only for upstream network from point of connection. For an example: if an ICC is connected to an 11kV zone substation bus, only losses in the sub-transmission lines and zone substation transformers need to be considered.

When an asset is shared between Non-site specific load and an ICC or between more than one ICC, all the losses need to be allocated fairly based on the individual customer or zone substation peak demand. For an example: Consider a large customer with 10 MW peak demand is connected to a Zone substation with 14 MW peak demand and other load connected as well. Load flow studies shows that total losses in upstream Network due to the large customer and other connected load is 360kW, then the losses attributable to the large customer is:

$$360 \text{ kW} * 10 \text{ MW} / 14\text{MW} = 257 \text{ kW}$$

The site-specific DLFs (DLF ICC) are calculated for 3 Big Customers on Network. The load losses for these customers are calculated using load flow analysis based on the customers' forecast peak demand and network load data. The model includes directly connected network assets between the customer point of connection and the GXP/Ngawha Generators which are used to supply them. The No-Load losses for the zone substation transformers are added to the Load losses to get total losses. The total losses are allocated to an ICC and converted into energy losses per annum using LLF for that ICC. The DLF for an ICC then, calculated as follows:

$$\text{DLF ICC} = 1 + \frac{\Sigma \text{ Losses (kWh) attributable to an ICC}}{\Sigma \text{ Energy Consumption (kWh) for an ICC}} \quad \text{VII}$$

The losses and energy allocated to all ICCs are then removed from the total network losses and total network energy consumption. The remaining losses and energy are used to calculate the DLFs for each stage of the network as follows:

$$\text{DLF} = 1 + \frac{\Sigma \text{ Losses (kWh) for section of Network – ICC losses}}{\Sigma \text{ Energy Consumption (kWh) for all section downstream including that section – ICC consumption}} \quad \text{VIII}$$

The following sections present the methodology to calculate energy losses for each hierarchical stage of TEN.

## 6.3 Sub-transmission Network (33kV lines)

Load flow studies for both northern and southern 33kV network are performed to calculate the Load losses in 33kV lines at network peak demand. The forecast peak demand for each 33/11kV substation is used.

The LLFs are calculated at both GXPs from respective 30 minutes averaged zone substation SCADA data and applied to the load losses of 33kV lines supplied from each GXP to calculate associated energy losses as per Equation I.

## 6.4 Zone substation

Full zone substation models for all zone substations are developed and Load flow studies using the forecast peak demand for each 11kV distribution feeder at respective zone substation are performed to obtain the Load losses at peak demand.

The LLFs are calculated for each zone substation using 30 minutes average feeder SCADA data. The LLFs values for zone substations in northern and southern networks are then averaged individually to obtain single LLF value for respective network. These LLFs then applied to zone substation load losses to calculate associated energy losses.

The No-Load losses for all zone substation transformers are obtained from manufacturer's data sheets and Test sheets. The energy losses associated with No-Load losses of the zone substation transformers are calculated as per Equation II.

The total zone substation losses are then added with upstream losses (sub-transmission line losses) to calculate the DLF at zone substation level.

## 6.5 HV Network (22/11/6.35 kV Lines)

Top Energy's HV Network is modelled using GIS data. The backbone models for all the feeders in TEN are modelled at 11kV bus of respective zone substation. The models also include 2 wires and SWER lines along with its isolating transformers. All the spurs with length less than 500m are not included in the models for simplicity of the network model. All the distribution transformers and above mentioned spurs are modelled as lump load on HV feeder. Load flow studies are performed on all the feeders using corresponding forecast peak demand to obtain the Load losses.

The LLFs for respective zone substation, as per Equation V, are applied to HV feeders supplied from respective zone substation to obtain associated energy losses on each feeder as mentioned in Section 4.2. Energy losses for all distribution feeders in the Network are then aggregated and added to upstream losses to calculate DLF for HV Network.

## 6.6 Distribution Transformers

The Load and No-Load losses incurred at rated MVA in different size of distribution transformers are obtained from Manufacturer's datasheet and Test sheets. The average losses are calculated for each type and size of transformers including SWER isolating transformers. The average utilization factor for entire Top Energy Network is used to calculate the Load Losses as follows:

$$\text{Load Losses} = \Sigma (\text{Losses at Rated MVA}) * (\%UF)^2$$

The numbers of each size of transformer are obtained from Top Energy's GIS database as disclosed in Top Energy's Asset Management Plan-2007.

It has been noticed that average utilization factor for Top Energy's distribution transformers is approximately 30% for transformers up to 300kVA and approximately 40% for transformers above 300kVA. This information is obtained from randomly taken transformer load logging data on entire network. As Top Energy does not have maximum demand indicators on its distribution transformer, these randomly taken load logging data are considered to be the most reliable data.

The LLFs for northern and southern network zone substations are then averaged to get one value for entire TEN. The energy losses for the Load and No-load losses are then calculated as shown in Section 4.2.

The DLF calculation for distribution transformers will be carried out periodically for any changes in network topology, no of transformers and loading.

## 6.7 Low Voltage Network

The DLF at LV network level is then calculated using energy losses obtained as per Section 4.3.

## 6.8 Embedded Generator

EGR require to calculate site specific DLF for an embedded generating unit with actual generation of more than 10MW. Ngawha Geothermal power station with 10MW (2 x 5MW) total generating capacity is connected using a 10km 33kV line at Sub-transmission level on TEN. This section defines the methodology used to calculate DLF for Ngawha Generators.

The methodology considers all the generators as a single group and calculates overall impact on total network energy losses, using a type of marginal approach. The overall reduction or increase in energy losses caused by a group of embedded generators is then allocated to each generator based on generating capacity of individual generator. The DLF for generator is then calculated as follows:

$$\text{DLF} = 1 + \frac{\Sigma \text{ Energy Loss Reduction/ Increase}}{\Sigma \text{ Energy Generated}} \quad \text{IX}$$

To analyse the total impact on energy losses on TEN due to Ngawha generators, Load flow study is performed with and without both generators connected to TEN and network losses are calculated for both the cases. The difference in the total network losses is calculated and converted to energy losses per annum using LLF values for Ngawha generators. The difference in losses is not allocated to each generator as mentioned above as both the generator units are of identical size. The total energy generated is obtained from metering data for power station. The DLF for Ngawha is then calculated using above formula.

It has been noticed that, the Ngawha generation neither increases nor decreases the losses on TEN. As a result of that DLF for Ngawha is 1. However, the TEN customers are still benefited from the generators, as they do not have to pay for the losses which would have incurred on Transpower network in absence of Ngawha generation.

## 7. Reporting

Once all the DLFs are calculated and applied to appropriate voltage level, reconciliation calculation is performed for the pervious year energy injection and consumption data.

A report detailing loss factor calculation methodology and the detailed DLFs, reconciliation and losses for each voltage level is prepared each year for submission to the Commission. This report must be submitted prior to 1 March of each year regardless of any change or not.

## 8. Summary:

This section summaries the loss calculation methodology and the DLF for each stage of the network.

Table 1 below shows summary of the method applied to calculate losses for individual losses.

Loss Type	Losses Applied to	Load Losses	No-Load Losses
Reconciliation Losses	Entire Network	Total Network injection - Total Network consumption	
Technical Losses	Sub-Transmission Network (33kV Lines)	Using DigSilent PowerFactory Simulation	N/A
	Zone Substation		Using Manufacturer's Data sheet and Test sheets
	HV Network (22/11/6.35kV Lines)		N/A
	Distribution Transformers	Using Transformer count, % Utilisation Factor, Manufacturer's Data sheets and transformer Test sheets	Using Manufacturer's Data sheet and Test sheets
Non-Technical Losses	LV Network	Reconciliation Losses - Upstream losses.	

**Table 1: Loss Calculation Methods for Each Stage of Network**

Loss Type	Loss Factor Code	Applied to Customer Connected to	Individual DLF	Cumulative DLF
Reconciliation Losses	DLF R	Entire Network (Reconciliation)	N/A	1.104
Technical Losses	DLF A	Sub-Transmission Network (33kV Lines)	1.022	1.022
	DLF B	Zone Substation	1.005	1.027
	DLF C	HV Network (22/11/6.35kV Lines)	1.036	1.063
	DLF D	Distribution Transformers	1.018	1.082
Non-Technical Losses	DLF E	LV Network (Non-Technical + LV)	1.022	1.104
Site-Specific Customers	DLF I1 (JNL)	Site-Specific Customers	N/A	1.015
	DLF I2 (AFFCO)	Site-Specific Customers	N/A	1.039
	DLF I3 (NZCC)	Site-Specific Customers	N/A	1.062
	DLF G1 (NGA)	Site-Specific Customers-Generators	N/A	1.000

**Table 2: DLF Values for Each Stage of Network and Site-Specific Customers**

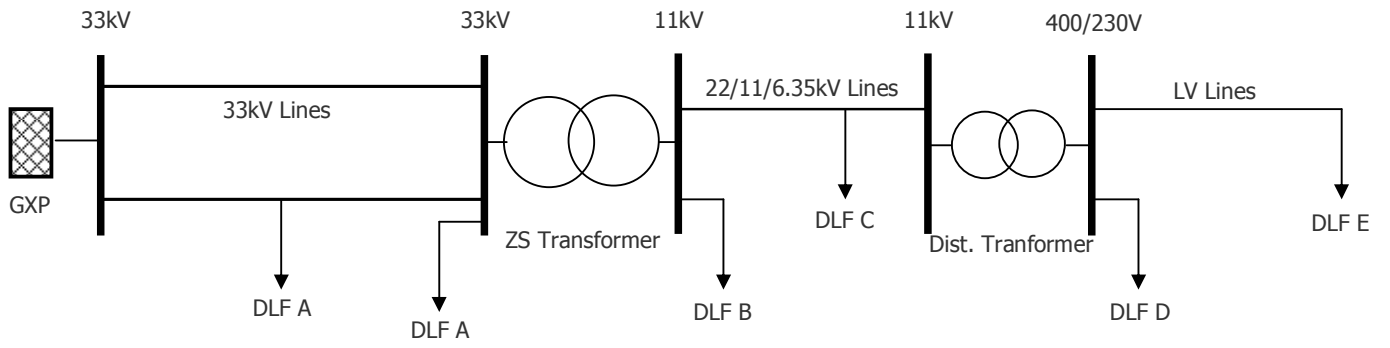

**Figure 1: DLF Application at Different Network Stages**

Figure 1 represents the application of the DLFs at different network stages. This figure does not represent the application of site-specific DLFs.